



White Paper

An Industrial Workflow for Scalable Micro- and Nanostructures

Combining Lithographic Origination, Electroforming Tooling, and Roll-to-Roll UV-Nanoimprint Replication

Abstract

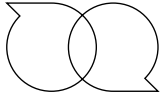

Jointly developed by Himax IGI, 3D AG, and polyscale innovations GmbH, this white paper outlines an end-to-end fabrication workflow designed to scale micro- and nanostructures from concept to industrial production. The workflow initiates with Himax IGI, leveraging large-area lithographic origination on glass substrates. This is followed by the tooling phase at 3D AG, where electroforming is used to produce high quality nickel shims. These shims are subsequently converted into cylindrical sleeves through specialised precision laser welding and forming techniques.

The final stage is executed by polyscale innovations GmbH, focusing on industrial nanoimprint replication and rigorous quality control for structural fidelity and scalability. Analysis of the replicated microstructures demonstrates exceptional precision:

- **Angular accuracy:** Deviations between microstructures are limited to $\pm 0.32^\circ$
- **Planar dimensions:** Accuracy is maintained within $\pm 0.39 \mu\text{m}$
- **Vertical fidelity:** Reproducible structure height accuracy of $\pm 0.12 \mu\text{m}$

This collaboration successfully integrates three specialised technical domains - origination, tooling, and volume replication into a synchronised industrial process. The results validate that clearly defined interfaces and unified quality standards enable a reliable transition from complex laboratory designs to high-volume, industrial-grade manufacturing.

Content

04	Introduction
06	Microstructure Design by polyscale innovations GmbH Optical Simulation
08	High-Precision Origination on Large-Area by Himax IGI Substrates Patterning with Greyscale Lithography Applying the Process to a Novel Design
10	Electroforming for Sleeve Production by 3D AG Process Overview Shim Family: Generations for Sustainable Replication From Flat Shims to Cylindrical Sleeves
14	Industrial Replication of The Structures: UV-nanoimprint Lithography Process by polyscale innovations GmbH Process Principles Materials and Formulation Flexibility Characterization Replication of Electroformed Sleeves
19	Conclusion: A Unified Path to Scalability
20	About the Authors
22	About the Partners

Introduction

Micro- and nanostructured surfaces have become fundamental to modern technological advancement, offering unprecedented control over physical and optical properties. By engineering surfaces at the micro- and nanoscale, it is possible to achieve advanced functionalities such as high-efficiency light guiding, anti-reflective properties, and bio-mimicking effects like hydrophobicity or structural colouration. These engineered surfaces are critical to the development of next-generation displays, high-performance sensors, and medical devices. However, the primary challenge remains the transition of these complex designs from controlled laboratory environments to high-volume industrial production without compromising structural integrity.

Transitioning complex designs from a controlled laboratory environment to high-volume industrial production requires a robust manufacturing chain where structural integrity is maintained across every interface. This white paper details a strategic collaboration between Himax IGI, 3D AG, and polyscale innovations GmbH, demonstrating a cohesive, high-precision workflow designed to bridge this gap and support true industrial upscaling.

The process begins at Himax IGI, where large-area micro- and nanostructures originated on glass substrates utilising advanced lithography techniques. These master patterns define the fundamental functional geometry and serve as the high-fidelity master for the entire downstream production sequence.

Once the master structures are originated, they are transferred to 3D AG for the critical tooling phase. Through high-precision electroforming, the surface geometries are translated into durable nickel shims. 3D AG manages the generation of secondary tooling and, where necessary, the recombination of structures. These shims are subsequently transformed into cylindrical sleeves using a specialized combination of precision laser cutting, forming, and pulsed-laser welding. This conversion is the pivotal step that enables the transition from flat master patterns to continuous, high-speed roll-to-roll replication.

The final stage of the chain is managed by polyscale innovations GmbH, which integrates these precision sleeves into industrial-scale nanoimprint replication environments. Polyscale focuses on the actual manufacturing output, evaluating how the structures behave under industrial process conditions and ensuring that the final replicated surfaces meet the requirements for large-volume commercial applications.

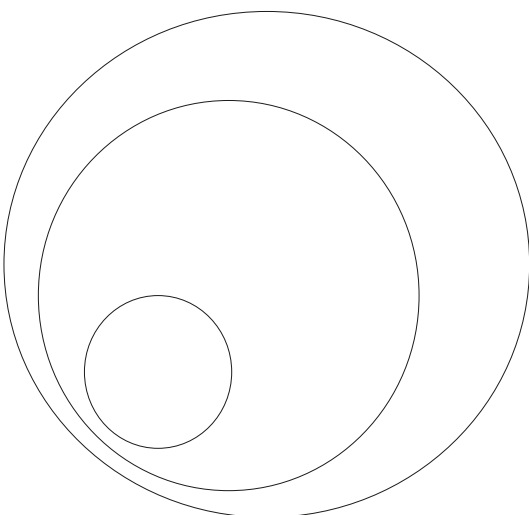

Optical Simulation

Optical simulation plays a crucial role in designing micro- and nanostructures to achieve specific optical functions and meet end-user requirements. Advanced software tools enable the modeling of how light interacts with complex surface geometries, predicting properties such as light distribution, intensity, color uniformity, and glare control.

By virtually testing different structural designs, parameters like feature size, shape, and arrangement can be optimized to tailor optical effects precisely, for example, creating diffusers, light-guiding structures, or decorative patterns. This simulation-driven approach significantly accelerates development cycles, reduces prototyping costs, and ensures that the fabricated structures deliver the desired performance in real-world applications, such as in lighting, displays, or optical sensors.

For this collaboration, polyscale innovations GmbH conducted the optical design and simulation work using LightTools, modelling a microstructure intended to provide effective glare reduction. A hexagonal array of oval cone-shaped features was generated, with structure angles ranging from 30° to 36° and a feature height of 10 μm (see Figure 1). The simulations enabled rapid iteration of design parameters and provided clear predictions of how the final replicated structures would influence optical behavior in the target application. The geometric description of the final simulated structure was provided to Himax IGI for the lithographic origination fabrication.

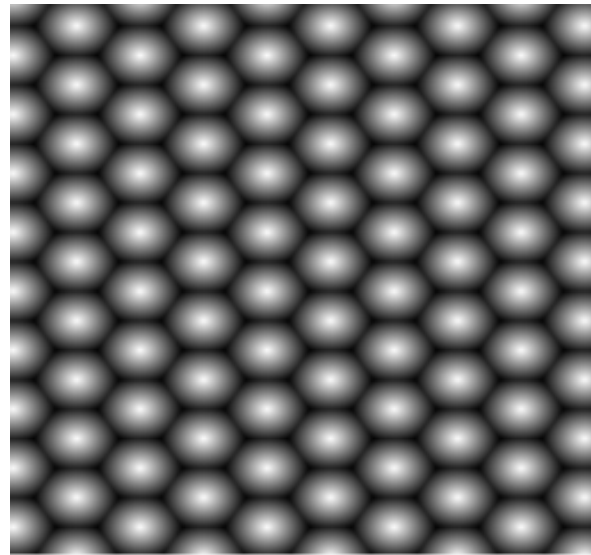

Figure 1: Gray scale image of the hexagonal arrangement of the oval cone shapes microstructures.

The simulation results are presented as light distribution curves (LDCs) for C0 and C90 directions, illustrating how the designed microstructure shapes the emitted light in both principal orientations in terms of glare reduction (Figure 2). These curves provide a direct comparison of the angular light output and highlight the directional control achieved by the simulated geometry.

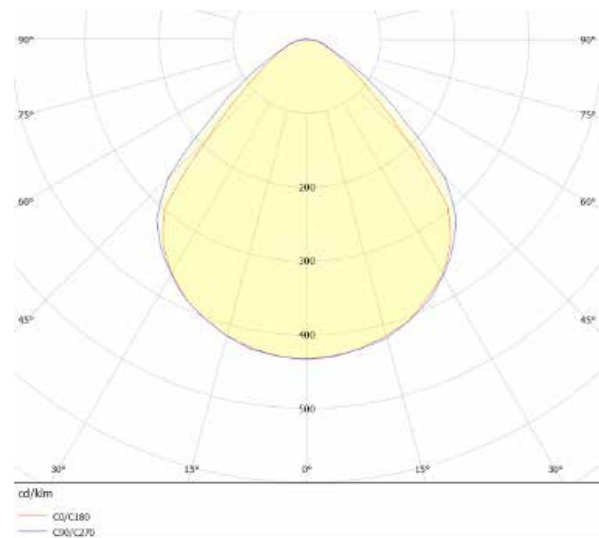

Figure 2: Simulated light distribution curve (LDC) for C0 and C90 directions of the oval cone shaped microstructures.

Substrates Patterning with Greyscale Lithography

While there are several fabrication methods available for the patterning of three-dimensional microstructures, most have limitations at and beyond wafer-scale production. To achieve a high-quality large-area origination, Himax IGI utilizes direct-write greyscale photolithography, enabling the creation of intricate features with excellent uniformity and scalability.

Producing these types of structures through greyscale photolithography requires the precise exposure of a photosensitive polymer, or photoresist, such that only the desired amount of photoresist is removed after a development process. To do this, photoresist is deposited on the substrate to form a planar surface, and then the resist is then soft-baked to remove residual solvent. The resist is then exposed at varying intensities over the pattern area with a 405 nm laser, causing a photochemical reaction in the volume of the resist exposed to the laser. When immersed in an aqueous-alkaline developer, the pattern is revealed through the removal of the intended amount of photoresist from the surface (Figure 3).

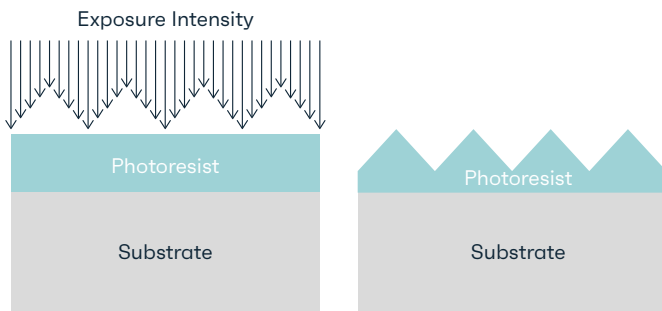

Figure 3: A laser intensity gradation is utilised during photolithography, which, after development, produces the three-dimensional pattern in the photoresist.

Resist contrast and sensitivity are measured, and three-dimensional biases are applied to ensure that the resulting resist profiles match well with the design data. Stitching errors are mitigated or eliminated entirely with proprietary compensation approaches. This methodology applies to fabrication at both the wafer scale and large-area originations. Once patterned, the large-area origination is then hard-baked to increase the material's durability during the subsequent electroplating process.

Applying the Process to a Novel Design

Once the optical design of the deglaring microstructure was finalized by polyscale innovations, cone angles, pitches, and other relevant parameters were provided to Himax IGI for lithography data preparation. Test patterns were fabricated, measured with confocal microscopy, and compared back to the design data to identify the data compensations and process parameters necessary to achieve the highest possible pattern fidelity.

Once the testing process was complete, the compensated design data was expanded to a total area of 550 mm x 600 mm (Figure 4) – wherein the cone deglaring structure is repeated without seams or interruptions – and the origination was fabricated on a substrate measuring 600 mm x 810 mm.

Confocal microscopy conducted on the origination confirmed that the microstructures matched the design data well throughout the entirety of the patterned area.

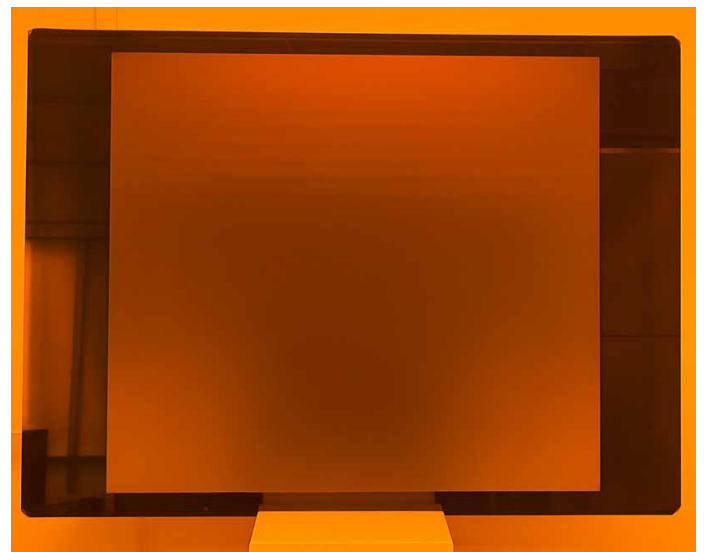

Figure 4: Completed photoresist origination transferred to 3D AG for electroforming.

Completed photoresist origination transferred to 3D AG for electroforming.

Once the micro- and nanostructures are created, they must be embedded within a rigid, stable material. This is accomplished through electroforming, a metal deposition process in which a layer of nickel is grown directly onto the patterned base material. Electroforming is unparalleled in its ability to replicate micro- and nanostructures with nanometre-scale accuracy, enabling the production of high-precision nickel shims and, ultimately, durable cylindrical sleeves. Almost any structured substrate provided by partners can serve as the starting point, giving electroforming a level of flexibility that ensures consistency and precision throughout the entire replication chain.

Process Overview

The process involves immersing an anode and a cathode in an electrolytic bath and passing a direct current through the solution. This causes metal ions to migrate and deposit onto the cathodic surface, ultimately plating the metal onto the base material. Electroforming is a specialized form of electrodeposition that produces a relatively thick metal layer, typically ranging from 50 μm to approximately 4000 μm . This layer can then be separated as a nickel shim, creating an accurate replica of the original structure. Figure 5 shows a schematic of the electroforming tank.

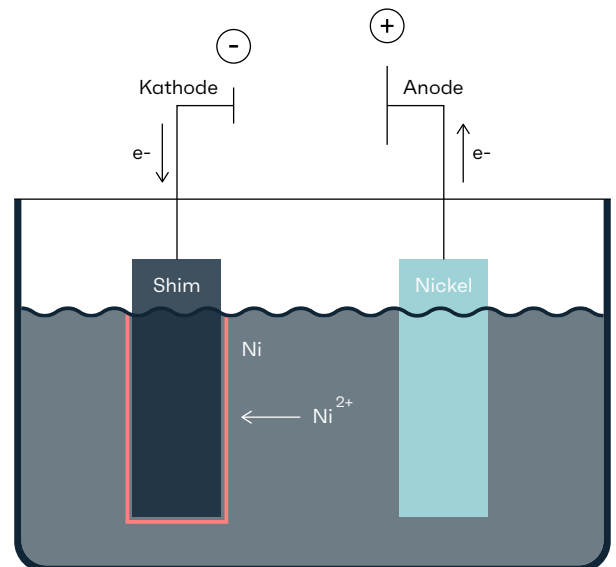

Figure 5: Schematic drawing of nickel electrodeposition. Nickel ions are transferred from nickel pellets to a metalised base material and form a nickel shim.

Shim Family: Generations for Sustainable Replication

A key advantage of electroforming is the ability to create multiple, identical shim copies from a single master. This is essential for industrial manufacturing, where tooling durability and reproducibility are critical.

A shim family typically follows this structure:

- Master template (from Himax IGI)
- Seeded master template (to ensure conductivity)
- Master shim (Gen. 1)
- Submaster Shims (Gen. 2)
- Sub-submaster Shims (Gen. 3)
- Production shims (Gen. 4) used to build sleeves or inserts

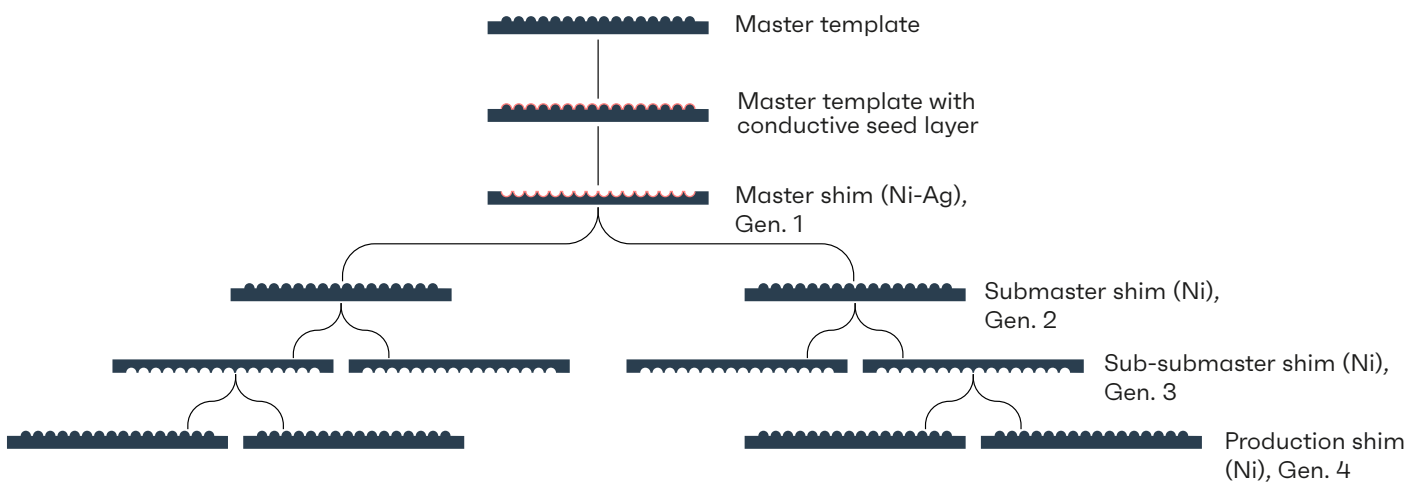

Figure 6: Nickel shim family, from master to multiple submaster and production shims. Parallel copies are possible to preserve the master for a larger number of subsequent copies.

This generational approach protects the original master structure while allowing parallel manufacturing of sleeves and flat tooling.

From Flat Shims to Cylindrical Sleeves

In this collaboration, 3D AG converted high-fidelity electroformed nickel shims into high-precision cylindrical sleeves, the preferred tooling format for continuous roll-based or rotary replication. To ensure mechanical stability and flexible forming, the process utilizes shims with a thickness of 150 - 200 μm , a maximum total thickness variation (TTV) of 5%, a homogeneous grain structure and low inner tension. The workflow involves laser-cutting these shims to precise dimensions and joining them using microscopic laser welding, a method specifically optimized for thin nickel to provide controlled heat input and minimal distortion. This precision preserves the integrity of micro- and nanostructures, while machine vision provides continuous quality inspection of the weld seam, ensuring a reliable tool for high-end manufacturing. The welding process involves continuous quality inspection of the seam by the machine vision. An image of the sleeve seam is presented in Figure 7.



Figure 7: QC picture from the machine vision system of the welding system

For this specific sleeve, 3D AG electroformed shims with 200 μm thickness. The welding process resulted in a seam width of approximately 180 μm . The characterization was performed with Keyence laser profilometer and are presented in Figure 8.

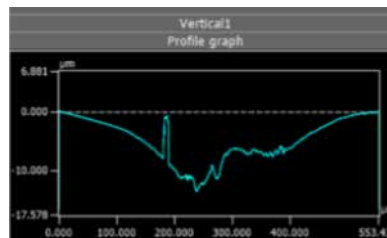
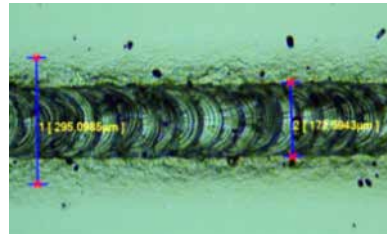

Figure 8: Measurements of the sleeve width and its profile.

The completed sleeve is shown in Figure 9. After a rigorous visual quality control process, the sleeve is ready to be transferred to polyscale innovations GmbH for further processing.



Figure 9: Laser welded sleeve during the optical inspection.

Ultraviolet (UV) nanoimprint lithography (UV-NIL) is widely established as a roll-to-roll (R2R) replication technology, offering exceptional potential for continuous, large-area manufacturing of micro- and nanostructured films. As demonstrated in industrial implementations of R2R UV-NIL, this approach combines high-resolution patterning with scalable throughput, making it a powerful tool for transferring functional structures from structured drums or master sleeves to flexible substrates in a cost-efficient manner.

Process Principles

R2R UV-NIL is based on imprinting a structured mold into a UV-curable photopolymer, which is subsequently crosslinked under UV light. The mold may be implemented either as a directly structured drum produced by diamond turning or laser structuring or as an electroformed nickel sleeve mounted on a drum. As the substrate film passes through the imprinting zone, a precisely controlled layer of UV-curable lacquer is applied to the film via slot-die coating. Contact between the structured drum and the liquid lacquer enables capillary filling and pressure-assisted replication of the drum's surface features.

UV exposure cures the lacquer in situ, solidifying the imprinted structures while the substrate film continues to advance. After curing, the structured film cleanly detaches from the drum, allowing continuous, uninterrupted roll-to-roll operation. This process achieves excellent pattern fidelity for feature sizes ranging from below 100 nm to several hundred micrometers, even over large substrate widths. A schematic representation of the R2R UV-NIL process is shown in Figure 10.

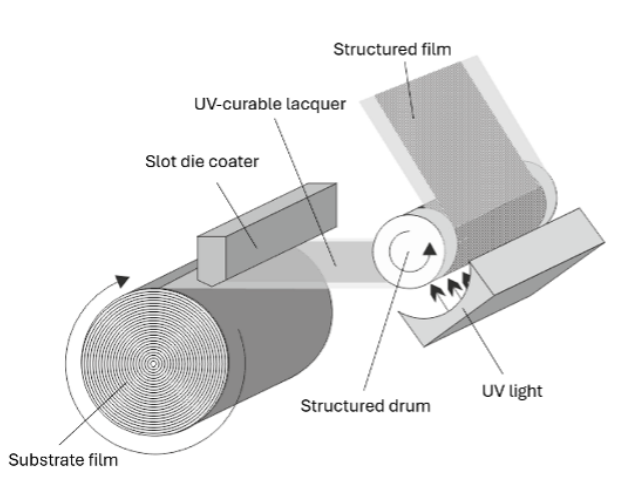

Figure 10: Schematic representation of the roll-to-roll (R2R) UV-nanoimprint lithography (UV-NIL) process used at polyscale innovations GmbH.

Materials and Formulation Flexibility

The performance of UV-NIL strongly depends on the interplay of substrate and lacquer chemistry. Commonly used substrates include polyethylene terephthalate (PET) and polycarbonate (PC), selected for their mechanical robustness, optical clarity, and compatibility with web-based processing. Substrate thicknesses of 50 - 500 μm can be processed.

The UV-curable lacquer - typically a photopolymer blend - is formulated to achieve the required mechanical and optical characteristics. Adjusting the lacquer composition allows precise tuning of properties such as hardness, adhesion, refractive index, and transparency. Functional additives can further introduce specific surface properties, enabling films designed for optics, sensing or anti-counterfeiting.

Characterization

Ensuring the precision and functional performance of replicated micro- and nanostructures requires a comprehensive characterization workflow. High-resolution microscopy plays a central role: laser scanning confocal microscopy provides three-dimensional surface maps with sub-micron accuracy, enabling detailed assessment of feature height, width, pitch, and overall pattern fidelity. These measurements also allow verification of uniform replication over large web widths, ensuring that the R2R UV-NIL process maintains structural consistency throughout production. Optical characterization techniques complement the structural analysis. UV-Vis spectrophotometry, refractometry, and angular-resolved measurements can be employed to quantify transparency, reflectance, refractive index, and other optical properties relevant to the final application. Such data confirm that both the substrate and the cured lacquer meet performance targets and that the replicated microstructures deliver the desired optical response. Beyond fundamental measurements, the optical function of the structured film can be evaluated according to end-user requirements using methods such as goniophotometry, luminance cameras, and practical assessments in prototype luminaires. These evaluations help determine how the structured films influence light distribution, brightness,

glare control, and overall visual experience, ensuring the final product meets both technical specifications and user expectations. Together, structural and optical characterization form a rigorous feedback loop that supports process optimization, ensures manufacturing consistency, and validates that the replicated films fulfil both technical specifications and end-user expectations.

Replication of Electroformed Sleeves

For this collaboration, we used the R2R UV-NIL process at polyscale innovations GmbH to imprint the microstructured sleeve, whose structure was originally produced using grayscale lithography by Himax IGI and transferred into a nickel sleeve by electroforming at 3D AG. The electroformed nickel sleeve is mounted onto an air bearing drum and inserted in the R2R UV-NIL machine. An acrylic lacquer was used on a 250 μm thick PET substrate to imprint the microstructures. For demonstration purposes for this white paper, a length of 50 m of imprinted material was produced, with an additional protective film applied during the process to protect the microstructures (see Figure 11).

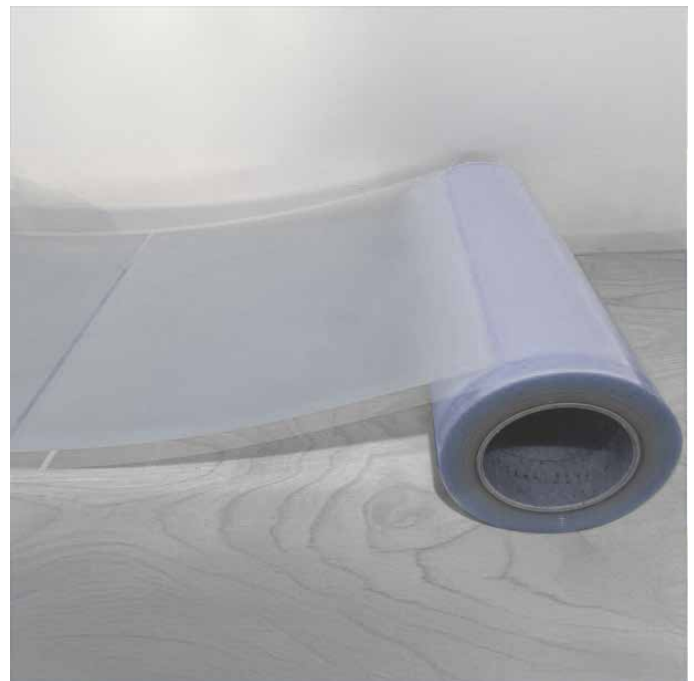

Figure 11: Photograph of imprinted roll.

To evaluate replication fidelity, confocal microscopy measurements were performed on the lithographic origination, the electroformed shim and the corresponding imprinted film. Quantitative values for key structural parameters, including feature angles, height, and pitches, were extracted from the confocal datasets for the origination, shim and imprinted film. To illustrate the microscopy results, the following Figures 12a, 12b, 12c present a comparative compilation of measurements taken at one representative position on the origination, the shim, and the imprinted film.

The resulting surface topographies allow a direct visual comparison of the structural profiles, demonstrating the accuracy of each processing step and confirming that even fine geometric features are precisely transferred from the origination, through the nickel sleeve, to the cured lacquer on the imprinted film.

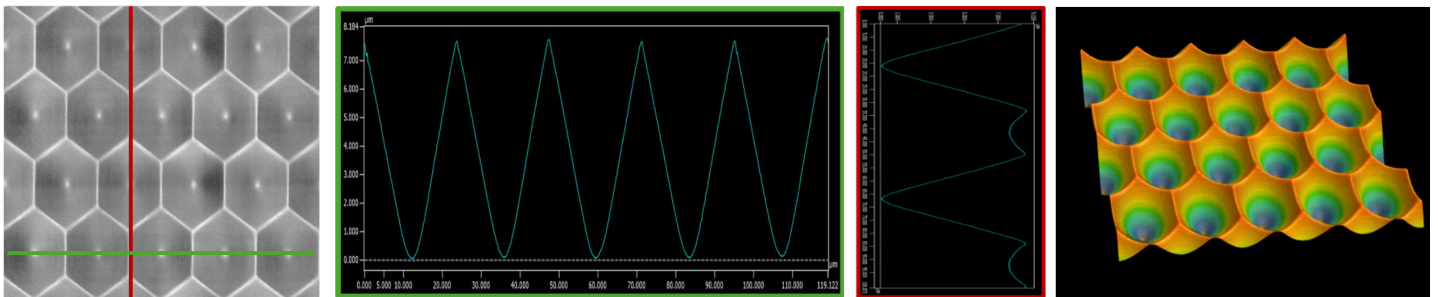

Figure 12a: Lithographic origination, Himax IGI (negative of final structure).

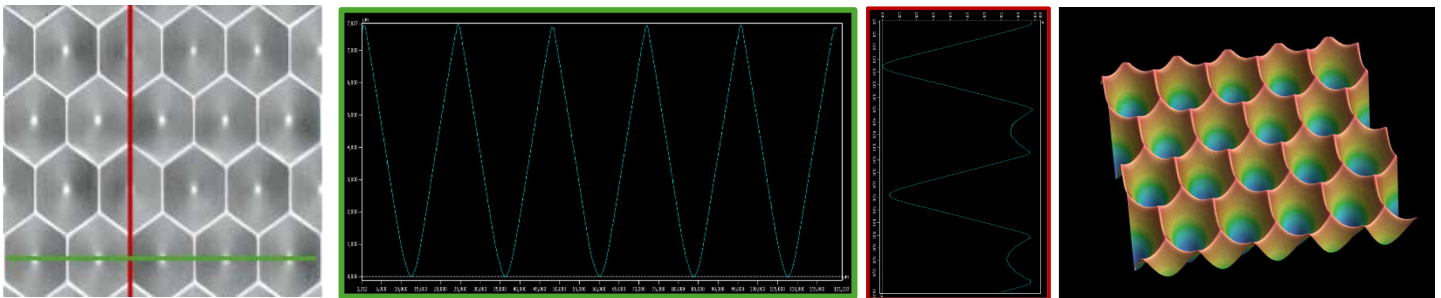

Figure 12b: Nickel shim, 3D AG (negative of the final structure)

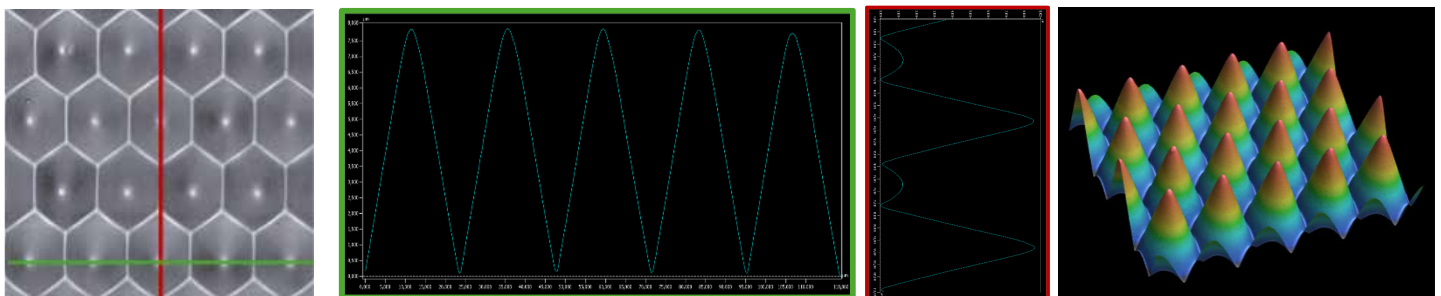

Figure 12c: Imprinted film, polyscale innovations GmbH (positive of final structure)

Figure 12a, 12b, and 12c: Comparative compilation of confocal microscopy measurements taken at one representative position on the lithographic master, the nickel shim, and the imprinted film.

These results of the confocal analysis are summarized in the following Table 1, allowing a clear assessment of how closely the imprinted film matches the geometry of the original shim and master. The comparison shows that key structural parameters are transferred with high accuracy throughout the process chain. Structure angles are preserved within approximately $\pm 1^\circ$, and lateral feature dimensions (pitch) remain stable within $\pm 0.3 \mu\text{m}$ from design to replicated film.

Minor rounding of tip and valley features is observed along the process chain and represents a predictable, process-inherent effect of lithography, electroforming, and polymer replication. This rounding leads to a slightly reduced effective structure height compared to the designed geometry, while preserving the overall feature shape. As the effect is systematic and reproducible, it can be reliably considered and compensated for during optical design and simulation.

Parameter	Designed	Lithographic origination	Nickel shim	Imprinted film
Angle 1 (short side)	36°	37.04 ± 0.61°	36.92 ± 0.40°	36.40 ± 0.32°
Angle 2 (long side)	30°	30.75 ± 0.50°	30.20 ± 0.26°	29.75 ± 0.31°
Pitch 1 (short side)	23.8 μm	23.81 ± 0.02 μm	23.79 ± 0.11 μm	23.83 ± 0.21 μm
Pitch 2 (long side)	25.6 μm	25.45 ± 0.03 μm	25.60 ± 0.48 μm	25.71 ± 0.39 μm
Max Height	10 μm	8.99 ± 0.34 μm	8.59 ± 0.06 μm	8.62 ± 0.12 μm
Tip radius	-	3.22 ± 0.19 μm	2.49 ± 0.08 μm	3.34 ± 0.29 μm
Valley radius	-	0.33 ± 0.17 μm	2.00 ± 1.25 μm	2.11 ± 0.68 μm

Table 1: Overview of measured values for key structural parameters, including feature angles, height, and pitches for lithographic origination, nickel shim and imprinted film.

Conclusion:

A Unified Path to Scalability

This collaboration between Himax IGI, 3D AG, and polyscale innovations GmbH successfully demonstrates a seamless, end-to-end industrial workflow for scaling complex microstructures from design to mass production. By aligning Himax IGI's large-area origination, 3D AG's high-precision sleeve tooling, and polyscale's roll-to-roll replication, the project proves that distinct technical domains can operate as a single, unified manufacturing chain.

The results confirm that high structural fidelity is maintained throughout the entire process, with critical dimensions and angles preserved from the initial master to the final replicated film. This integrated approach removes the traditional bottlenecks of scaling, offering a reliable and efficient blueprint for industries seeking to bring innovative optical and functional surfaces to the global market at scale.

About the Authors



Glen de Villafranca

Engineering Manager at Himax IGI

Glen joined Himax IGI in 2018 and has served as Engineering Manager since 2022, where he has led the expansion of Himax IGI's origination and 3D-structuring capabilities. Prior to joining Himax IGI, he worked as an analyst supporting the Office of Naval Research's Future Naval Capabilities program. He received his master's degree in Nanotechnology from the University of Pennsylvania, where he conducted research in nanolithography, and his bachelor's degree from Lehigh University's Integrated Engineering and Arts and Sciences program.



Dr. Marek Krehel

CTO at 3D AG

Dr. Marek Krehel, an Optical Engineer, joined 3D AG in 2017 and has been serving as the Chief Technology Officer since September 2022. He earned his doctoral degree in Engineering from ETH Zurich in 2014, focusing on Polymeric Optical Fiber for biomedical sensing at Empa. Following his doctorate, he worked as a Senior Research Associate at Luzern University of Applied Sciences, specializing in light redirection systems from 2014 to 2017. Prior to this, he contributed to Philips Research in Eindhoven, characterizing scattering systems in light-guiding applications. Dr. Krehel obtained his master's degree in this field from Wroclaw University of Technology.



Dr. Christoph Baum

CEO at polyscale innovations GmbH

Dr.-Ing. Christoph Baum is co-founder and CEO of polyscale innovations GmbH, where he applies his scientific and technological background to the development of micro-structured polymer and hybrid components for advanced optical applications.

He studied mechanical engineering at RWTH Aachen University, Universidad de Málaga (Spain), and Tsinghua University (China), and earned his Ph.D. at RWTH Aachen University with a focus on ultra-precision machine and process development.



Dr. Julian Neises

Head of R&D at polyscale innovations GmbH

Dr.-Ing. Julian Neises joined polyscale innovations GmbH in 2023 and has been head of the R&D department since January 2025. He earned his Ph.D. in 2023 at the Institute of Technology for Nanostructures at the University of Duisburg-Essen, where his research centered on temperature and fluid-dynamics simulations for excimer-laser processing of nanoparticulate silicon layers. He obtained his master's degree in NanoEngineering from the University of Duisburg-Essen.

About the Partners

Himax IGI

Himax IGI is a contract engineering company offering custom mastering and origination services, optical design, and replication based in Minneapolis, Minnesota. Our origination capabilities range from the wafer scale to seamless large-area patterns, from microscale structures to the nanoscale, from photolithography to electron-beam lithography, reactive-ion-etch pattern transfer, and more. We count on over 50 years of experience in photolithography and decades of experience in grayscale lithography.

Our customers have worked with us to develop products in the areas of:

- Micro-optics/photronics, including AR/VR, display, and 3D sensing
- Functional surface textures
- Security
- Microfluidics
- ... and more.

Himax IGI is a wholly owned subsidiary of Himax Technologies, Inc.

3D AG

With over 30 years of experience in micro and nanotechnology, 3D AG stands as a prominent tooling and process development company based in Switzerland. Specialising in mastering distinct processes for a diverse array of structures, our core competencies include electroforming high-quality nickel moulds up to 1,300mm x 1,800mm.

We excel in the step and repeat multiplication of structures, creating a larger area for mass-scale applications. Originally developed for upscaling nano security elements, our high-precision electroforming and recombination skills set us apart.

polyscale innovations GmbH

Polyscale innovations GmbH is a German technology company based in Aachen that develops, industrializes, and produces in series micro- and nanostructured surfaces and components for a wide range of specialized applications. The company combines deep production-technology expertise with optical design and simulation to support customers from early concept and development through prototyping and scalable series manufacturing.

A core strength of polyscale lies in the engineering of highly precise surface topographies on optical components, light guides, and functional films to achieve tailored optical and physical properties. This includes in-house mastering based on ultra-precision drum turning, followed by large-area replication using roll-to-roll UV nanoimprint lithography. Complementary downstream processes such as roll-to-roll PVD sputter coating and adhesive film lamination enable fully integrated functional layers and ready-to-use products.

With this end-to-end process chain, polyscale delivers robust, repeatable, and cost-efficient solutions suitable for industrial-scale series production.